

The **BA385-IIB** and **BA385-IIC** are second generation intrinsically safe field mounting sounders which produce a loud audible warning signal in a hazardous area. Thirty two different first stage alarm sounds can be selected by internal switches, and each one can be externally changed to a second or a third stage alarm sound. The three PFEER tones, Prepare to Abandon Platform, General Alarm and Toxic Gas Alarm are included. See tones 1, 11 and 31 in the sounder tone table.

Main application of the BA385 sounders is the generation of unique audible warnings within a hazardous area. The sounders may be powered from a wide range of Zener barriers or galvanic isolators, and may be controlled by any contact or dc supply in the safe area. They may also be switched in the hazardous area by an intrinsically safe relay, or any equipment with an intrinsically safe simple apparatus switch output, such as a BEKA 4/20mA indicator alarm. First, second or third stage alarms, which may be selected from within the safe or hazardous area, allow one sounder to indicate three different conditions.

A crystal controlled oscillator accurately defines the frequency and repetition rate of each alarm signal. This ensures that when

multiple BA385 sounders are activated at the same time, the output tones from all the sounders remain synchronised.

ATEX intrinsic safety certification permits installation in Zone 0, 1 or 2. The BA385-IIB is approved for use with IIA and IIB gases and the BA385-IIC, which has slightly less output, is approved for use with IIC, IIB & IIA gases.

A BA386 LED flashing beacon may be powered from the same Zener barrier or galvanic isolator as the sounder. This significantly reduces installation costs of a combined alarm system and only marginally reduces the sound output. See BA386 datasheet for full information.

The robust ABS enclosure which is flame-retardant, provides IP65 protection and is suitable for external surface mounting. Cable entry is via a single 20mm untapped hole which will accept a 20mm gland or conduit fitting.

Reliability is ensured by an ISO9001 approved quality control system supported by a three year guarantee. The BA385 is protected from input overloads and reverse connection, and complies with the European EMC Directive.

BA385-IIB and BA385-IIC

Audible Sounders

*Intrinsically safe for use
in all hazardous areas*

- *ATEX certification
IIB and IIC models*
- *32 first stage,
13 second stage
& 4 third stage
alarm sounds*
- *PFEER compliant*
- *Up to 105dB(A)
output*
- *Input overload
protection*
- *Volume control*
- *IP65 enclosure*
- *Can be powered
from BA386
flashing beacon*
- *3 year guarantee*



BEKA associates

BEKA associates Ltd. Old Charlton Rd.
Hitchin, Hertfordshire, SG5 2DA, U.K.
Tel. (01462) 438301 Fax (01462) 453971
e-mail sales@beka.co.uk www.beka.co.uk

SPECIFICATION

Power Supply

Voltage	8 to 30V Not damaged by direct connection to the supply without a Zener barrier or galvanic isolator in circuit.
Current	25mA typical when powered from 24V supply via 28V 300ohm Zener barrier.

Second and third stage alarms

Second stage	Connect terminals 2 and 4*
Third stage	Connect terminals 3 and 4* *If diode return barrier is used voltage drop must be less than 0.9V

Output

Sound level at 1m.	
BA385-IIB	Up to 105dB(A)
BA385-IIC	Up to 103dB(A)
Volume control	15dB(A) level reduction

Intrinsic safety

Europe ATEX

Standard	EN50020:1994
Code	Group II Category 1G
BA385-IIB	EEx ia IIB T4
BA385-IIC	EEx ia IIC T4

Cert. Nos.

BA385-IIB	BAS00ATEX1180 Ex98D2014 System Ex98D2016 System
-----------	-------------------------------------------------------

BA385-IIC

BAS00ATEX1181
Ex98D2013 System
Ex98D2015 System

Installation

The BA385-IIB and BA385-IIC may be powered from any certified Zener barrier or galvanic isolator whose output safety parameters do not exceed:

U _o	28V dc
I _o	110mA dc
P _o	0.8W

Location

Zone 0, 1 or 2

Tone number	Tone description	Switch settings 1 2 3 4 5	Second stage alarm	Third stage alarm
Tone 1	Continuous 1000Hz <i>Toxic gas alarm</i>	0 0 0 0 0	Tone 31	Tone 11
Tone 2	Alternating 800/1000Hz at 0.25s intervals	1 0 0 0 0	Tone 17	Tone 5
Tone 3	Slow whoop 500/1200Hz at 0.3Hz with 0.5s gap repeated	0 1 0 0 0	Tone 2	Tone 5
Tone 4	Sweeping 500/1000Hz at 1Hz	1 1 0 0 0	Tone 6	Tone 5
Tone 5	Continuous 2400Hz	0 0 1 0 0	Tone 3	Tone 27
Tone 6	Sweeping 2400/2900Hz at 7Hz	1 0 1 0 0	Tone 7	Tone 5
Tone 7	Sweeping 2400/2900Hz at 1Hz	0 1 1 0 0	Tone 10	Tone 5
Tone 8	Siren 500/1200/500Hz at 0.3Hz	1 1 1 0 0	Tone 2	Tone 5
Tone 9	Sawtooth 1200/500Hz at 1Hz	0 0 0 1 0	Tone 15	Tone 2
Tone 10	Alternating 2400/2900Hz at 2Hz	1 0 0 1 0	Tone 7	Tone 5
Tone 11	Intermittent 1000Hz at 0.5Hz <i>General alarm</i>	0 1 0 1 0	Tone 31	Tone 1
Tone 12	Alternating 800/1000Hz at 0.875Hz	1 1 0 1 0	Tone 4	Tone 5
Tone 13	Intermittent 2400Hz at 1Hz	0 0 1 1 0	Tone 15	Tone 5
Tone 14	Intermittent 800Hz 0.25s on, 1s off	1 0 1 1 0	Tone 4	Tone 5
Tone 15	Continuous 800Hz	0 1 1 1 0	Tone 2	Tone 5
Tone 16	Intermittent 550Hz 150ms on, 150ms off	1 1 1 1 0	Tone 18	Tone 5
Tone 17	Alternating 544Hz (100ms)/440Hz(400ms)	0 0 0 0 1	Tone 2	Tone 27
Tone 18	Intermittent 660Hz 1.8s on, 1.8s off	1 0 0 0 1	Tone 2	Tone 5
Tone 19	1400Hz to 1600Hz sweep up over 1s 1600Hz to 1400Hz sweep down over 0.5s	0 1 0 0 1	Tone 2	Tone 5
Tone 20	Continuous 660Hz	1 1 0 0 1	Tone 2	Tone 5
Tone 21	Alternating 554/440Hz at 1Hz	0 0 1 0 1	Tone 2	Tone 5
Tone 22	Intermittent 544Hz at 0.875Hz	1 0 1 0 1	Tone 2	Tone 5
Tone 23	800Hz pulsing at 2Hz	0 1 1 0 1	Tone 6	Tone 5
Tone 24	Sweeping 800/1000Hz at 50Hz	1 1 1 0 1	Tone 29	Tone 5
Tone 25	Sweeping 2400/2900Hz at 50Hz	0 0 0 1 1	Tone 29	Tone 5
Tone 26	Simulated bell	1 0 0 1 1	Tone 2	Tone 1
Tone 27	Continuous 554Hz	0 1 0 1 1	Tone 26	Tone 5
Tone 28	Continuous 440Hz	1 1 0 1 1	Tone 2	Tone 5
Tone 29	Sweeping 800/1000Hz at 7Hz	0 0 1 1 1	Tone 7	Tone 5
Tone 30	420Hz repeating 0.626s on, 0.625s off <i>Australian alert signal</i>	1 0 1 1 1	Tone 32	Tone 5
Tone 31	1200/400Hz at 1Hz <i>Prepare to abandon platform</i>	0 1 1 1 1	Tone 11	Tone 1
Tone 32	Sweeping 500/1200Hz 3.75s on, 0.25s off 15Hz <i>Australian evacuation signal</i>	1 1 1 1 1	Tone 26	Tone 1

DIMENSIONS (mm)

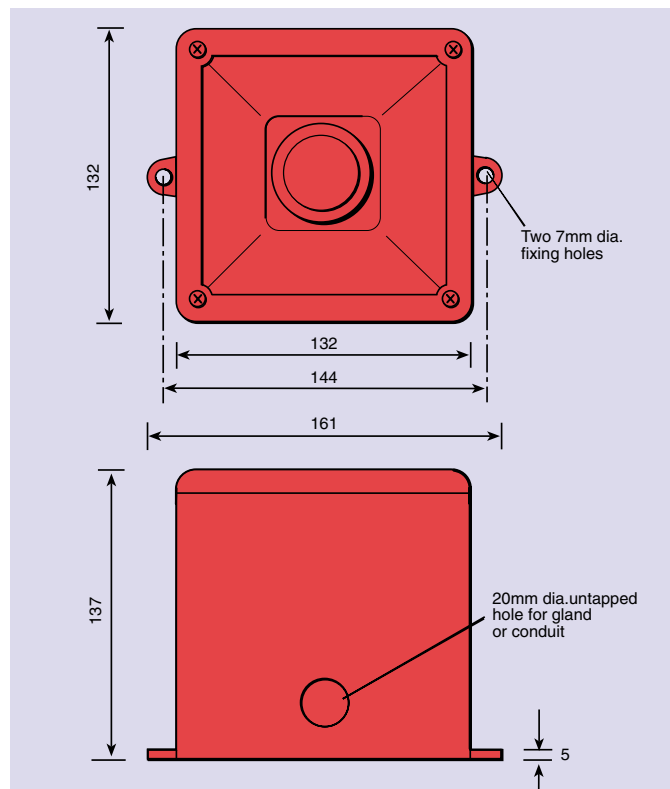

TERMINALS AND CONTROLS

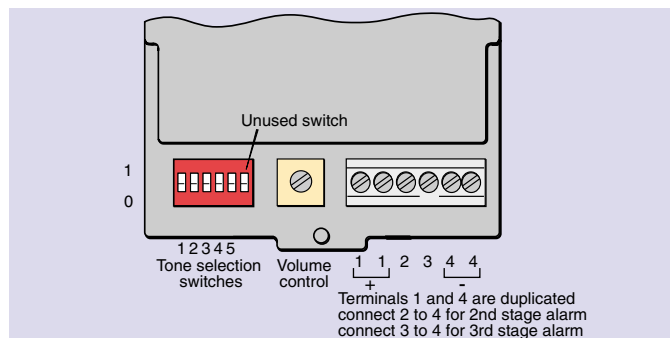

USA FM

Standard	3610 Entity
Code	
BA385-IIC	CLI, Div. 1, Gp A, B, C, and D
BA385-IIB	CLI, Div. 1, Gp C and D
Temperature code	T4 at 60°C
File No.	3001558
Standard	3611 Nonincendive
Code	
BA385-IIC	CLI, Div. 2, Gp A, B, C and D
BA385-IIB	CLI, Div. 2, Gp C and D
	Classified outdoor (IP65) locations
File No.	3001558

Environmental

Operating temp	-20 to +60°C (Certified for use at -40°C)
Humidity	To 95% at 40°C
Enclosure	IP65
EMC	In accordance with EU Directive 89/336/EEC, full report available.

Mechanical

Terminals	Screw clamp for 0.5 to 2.5mm ² cables
Weight	1kg

Accessories

Tag number	Thermally printed tag strip
------------	-----------------------------

HOW TO ORDER

Model number:

For IIA & IIB gases (Gp C&D)
For IIA, IIB & IIC gases (Gp A,B,C&D)

Accessories

Tag number

Please specify

BA385-IIB
BA385-IIC

Please specify if required

Legend